



Gaming and Censorship Regulation

Electronic Monitoring System

3rd Party Systems Interface

Discussion Document

**Version 0.3
June 2004**

Table of Contents

1.1	CHANGE RECORD.....	2
1.2	DOCUMENT PURPOSE.....	2
1.3	ACKNOWLEDGEMENT.....	3
1.4	REFERENCED DOCUMENTS.....	3
2	Introduction.....	4
2.1	BACKGROUND AND OVERVIEW.....	4
2.2	CURRENT SYSTEMS.....	4
2.3	OBJECTIVES.....	4
3	Interfaces to 3rd Party Devices.....	5
3.1	3 RD PARTY PROTOCOL STANDARD.....	6
3.2	GENERAL REQUIREMENTS.....	6
3.3	PHYSICAL INTERFACE.....	7
3.4	PHYSICAL LAYER.....	7
3.5	DATA LINK LAYER.....	7
3.6	APPLICATION LAYER.....	8
3.6.1	<i>Poll Messages</i>	8
3.6.2	<i>Response Messages</i>	9
3.6.3	<i>Broadcast Messages</i>	9
3.6.4	<i>Forward Request to EGM Response</i>	10
3.6.5	<i>Meters</i>	10
3.7	SECURITY.....	11
4	Specific 3rd Party Devices.....	12
4.1	CASHLESS GAMING SYSTEMS.....	12
4.1.1	<i>Background</i>	12
4.2	JACKPOT SYSTEMS.....	12
4.2.1	<i>Background</i>	12
4.2.2	<i>Jackpot Meters and Control Parameters</i>	13
4.3	VENUE MANAGEMENT SYSTEMS.....	13
4.3.1	<i>Background</i>	13
4.3.2	<i>Options</i>	13
5	APPENDIX A – Forward Request Function.....	15

1.1 Change Record

Version	Description	Date	By	Comments
0.1 – 0.3	Initial Drafts	30 Jun 04	P Targett	

1.2 Document Purpose

The purpose of this document is to propose and seek feedback on a method by which third party devices could be integrated into a QCOM based electronic gaming machine (EGM) monitoring system without changing the QCOM protocol.

This is not intended to be a definitive statement of requirements but is intended to initiate of discussions with suppliers of 3rd party devices on the

adoption of an open interface between 3rd party devices and the electronic monitoring system (EMS), as defined under the Gambling Act 2003 (the Act).

The information presented by the Department in this document is not intended to make any representations about a particular vendor or potential monitor, a particular system or timetable, or in relation to implementing the EMS.

1.3 Acknowledgement

This document is based on the Queensland Office of Gaming Regulation protocol QCOM. The original documents can be found on the QOGR website at:

<http://www.qogr.qld.gov.au/PUBLICATIONS>

1.4 Referenced Documents

1.	EGM Communications Interface and LAN Requirements	V2.0
2.	Local Area EGM Communications Protocol (QCOM)	V 1.5.5
3.	QCOM Protocol NZ modification	V3.0
4.	Site Controller Minimum Technical requirements	V2.0

Note: The current version for QCOM is 1.5.5 and V1.6 is under development by QOGR, it is anticipated it will be released in the near future. It is highly probable that this version will be adopted in New Zealand.

2 Introduction

2.1 Background and Overview

The Act requires the holder of a class 4 operator's licence to connect EGMs under the holders control to an EMS by the date or dated notified by the Secretary, but in any case no later than 18 March 2007 being the date 3 years and 6 months after the Act received Royal Assent.

The holder of a class 4 operator's licence must bear the cost of replacing or upgrading gambling equipment (including EGMs) in order to enable the connection of EGMs to an EMS.

2.2 Current Systems

Current jackpot and cashless systems interface to EGMs via a pulse wiring harness or in the instance of one jackpot system via a propriety 2-way protocol for the downloading of jackpot awards direct to the EGM software for player payment. The EGM treats the jackpot award as if it were a win awarded by the game and the player can either continue to play games on the machine or cash out and receive payment via the hopper or cancelled credit –an attendant cash payment. The EGM total wins meter records every jackpot awarded to the EGM electronically.

For the other type of jackpot system in use in New Zealand an attendant payment must be made for all winning jackpots awarded to the player. This information is recorded manually and is not available electronically. As such it has to be recorded by venues as a manual payment when calculating total venue gaming proceeds. There is no provision for venues to record this payment under a QCOM based EMS and it therefore would not be possible for a monitor to determine the total venue gaming proceeds.

Cashless systems do not effect EGM proceeds but are critical in functionality as an alternative way for players to download cash to a gaming machine and correspondingly download any wins to their account. The current technology is similar to jackpot connection via a pulse based wiring harness and is integral to EGM.

2.3 Objectives

It is proposed that a 3rd Party Interface be developed to allow possible connection of 3rd party devices to an EMS and provide monitoring and message transfer capabilities. The proposed protocol for the 3rd Party Interface would be similar to but separate to the QCOM protocol utilising the same physical network and hosted on the Site Controller.

3 Interfaces to 3rd Party Devices

The 3rd party devices considered in this discussion paper to be supported by an EMS Site Controller are:

- Cashless Gaming Systems
- Jackpot Systems
- Venue Management Systems

The QCOM specification does not support devices, other than EGMs, to provide information back to the EMS or for information to be passed from any other device, other than the Site Controller, onto the EGMs. This limits the ability to make electronic cash transfers to EGMs from 3rd party devices such as cashless systems or jackpots controllers. For QOGR this functionality has been provided directly by the Site Controller. However, this option is not envisaged for New Zealand. Alternatively an agreed open interface is proposed to be provided on the Site Controller that enables 3rd party devices to connect to the EMS and supply the necessary data to the EMS or request that it is forwarded to an EGM.

As the fibre optic network used for QCOM can be used to support other similar protocols and to provide a commonality in design, it is possible that 3rd party devices can be connected to the EMS through the fibre optic network used by the QCOM protocol. This approach is currently used in Queensland to support the I.G.T. protocol that co-exists and runs at a different bit data rate to the QCOM 19,200 baud and is also being used for other similar developments.

This physical interface could then support a data link layer and application layer similar to that adopted by the QCOM protocol. The additional benefit of taking this approach is the ability of any 3rd party devices attached to the system to passively monitor the Site Controller/EGM activity by ‘sniffing’ so enabling it to gather information, such as EGM meter readings.

It is proposed that a variant of the QCOM application layer be developed as a New Zealand open standard protocol for use by 3rd party device vendors to enable them to develop solutions that can be interfaced to the EMS.

If necessary, this approach would possibly enable integration with QCOM protocol, at a later date, rather than redesigning the interface and software.

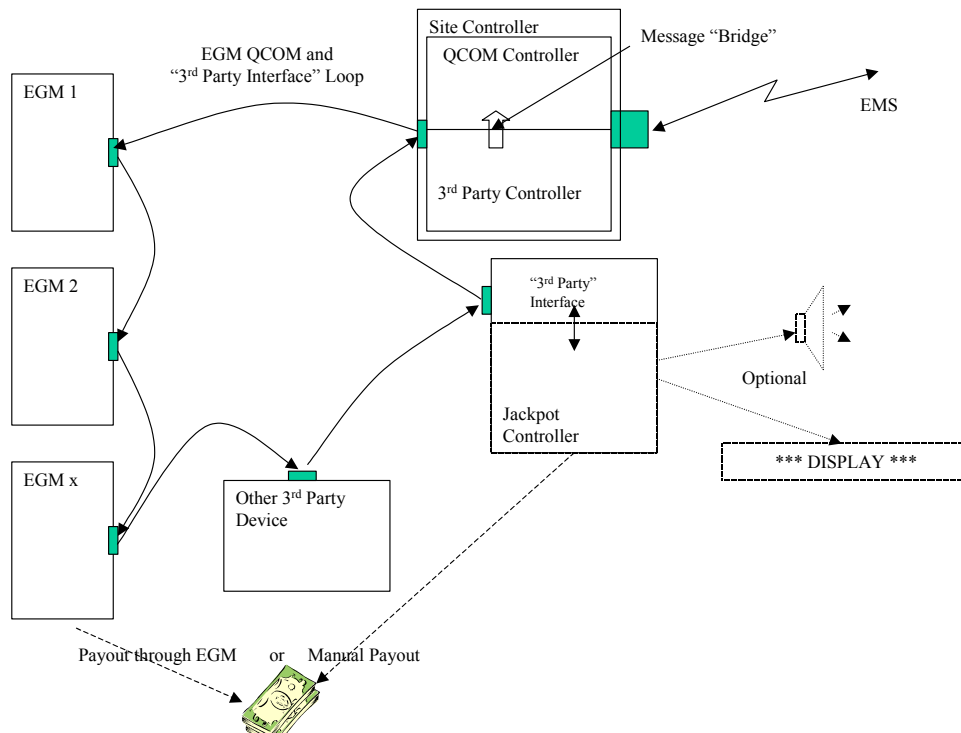

The Site Controller would host a 3rd Party Interface protocol controller that functions in a similar manner to the QCOM protocol controller but with a modified message data set. This controller application would also be the ‘bridge; between the 3rd Party Interface and QCOM allowing messages to be transferred from 3rd party devices to EGMs.

The 3rd Party Interface Controller application would perform the following functions:

- Establish the integrity or validity of the 3rd Party devices;
- Poll the 3rd Party devices for events and messages;
- Interpret the incoming messages
- Translate messages as metering data for onward transmission to the monitoring system; or
- Translate messages and forwarded the messages to the QCOM application for onward transmission to the appropriate EGM.

3.1 3rd Party Protocol Standard

It is proposed that 3rd Party Protocol Standard reflecting this proposed approach would be produced by DIA, based on the QCOM specification “Local Area EGM Communications Protocol (QCOM)”

3.2 General Requirements

It is proposed that the following general requirements apply to 3rd Party Interface Controllers:

- The 3rd Party Interface Controller should be separate to but co-exist with the QCOM controller on the Site Controller hardware;
- The 3rd Party Interface Controller and the QCOM controller would be separate software applications and designed in such a manner that the integrity of either application is not compromised by the other;
- The 3rd Party Interface Controller software would be able to be removed from the Site Controller or disabled without affecting the function of the QCOM Controller;
- The 3rd Party Interface Controllers would be integrated with the QCOM Site Controller by means of a communications ‘bridge’ between the two applications; and
- 3rd Party Interface Controller software would meet the same standards as those applied to the QCOM Controller.

3.3 Physical Interface

It is proposed that connection of 3rd party devices would be to the fibre optic loop implemented for QCOM connected EGMs, as defined in the document “EGM Communications Interface and LAN Requirements”.

3.4 Physical Layer

It is proposed that the communications Physical Layer would be as defined in section 13 of the document “Local Area EGM Communications Protocol (QCOM)” with the following exceptions:

- Data rates would be 9600 baud, or multiples thereof, excluding the 19,200 baud utilised by QCOM.
- Data rates would be configurable to any of the allowable rates other than 19,200 baud.

3.5 Data Link Layer

It is proposed that the communications Data Link layer implemented would be the same as that defined in section 14 of the document “Local Area EGM Communications Protocol (QCOM)” with the following exceptions:

- Although it may be preferable that EGMs communicate data directly to 3rd party devices this would require modification of the QCOM protocol. Therefore, monitoring of the QCOM data stream by ‘sniffing’ would be acceptable for approved 3rd party devices;
- The 3rd Party Interface Controller would synchronise itself to transmit its data into the QCOM data stream 250ms from the start of a poll or broadcast message from the QCOM Controller. (Note: At 9600 baud in the order of 240 bytes can be transferred in each 250ms frame and 720 bytes at 28,800 baud.); and

- Site Controller Transmissions into the QCOM data stream from 3rd party devices is not be acceptable under the QCOM protocol other than at the agreed baud rate for the 3rd Party Interface and in response to polls from the 3rd Party Interface Controller.

3.6 Application Layer

It is proposed that a variant of the QCOM application layer would be developed as a New Zealand open standard. This would be based on section 15 of the document “Local Area EGM Communications Protocol (QCOM)”. With the following exceptions:

3.6.1 Poll Messages

The following polls to 3rd Party devices would be supported (these are directly equivalent to the QCOM polls to EGMs):

Func Code	3rd Party Controller Poll Message	Equivalent QCOM Poll Message
0x33	3rd Party Configuration Request	EGM Configuration Request
0x31	3rd Party Configuration	EGM Configuration
0x2F	3rd Party Game Configuration	EGM Game Configuration
0x2E	3rd Party Variation Change	EGM Variation Change
0x2D	3rd Party Parameters	EGM Parameters
0x29	Program Signature Request	Program Signature Request
0x27	System lockup Request	System lockup Request
0x24	(Reserved)	(Reserved for ECT Operation - ECT Lockup Reset)
0x23	(Reserved)	(Reserved for ECT Operation - ECT from EGM Lockup Request)
0x22	(Reserved)	(Reserved for ECT Operation - ECT to EGM)
0x1E	Cancel Credit Lockup Request	Cancel Credit Lockup Request
0x1B	3rd Party General Maintenance Poll	EGM General Maintenance Poll
0x17	Request All Logged Events	Request All Logged Events
0x16	Purge Events	Purge Events
0x12	(Reserved)	(Reserved for DLSA - DLSA Lockup Acknowledgment)
0x11	(Reserved)	(Reserved for DLSA - DLSA Configuration)
0x10	(Reserved)	Note Acceptor Maintenance
0x0F	(Reserved)	Hopper/Ticket Printer Maintenance
0x0E	Linked Progressive Award Acknowledged	Linked Progressive Award Acknowledged
0x0C	3rd Party General Reset	EGM General Reset
0x08	Specific Promotional/Advisory	Specific Promotional/Advisory

	Message A	Message A
0x07	Specific Promotional/Advisory Message B	Specific Promotional/Advisory Message B
0x05	(Reserved)	EGM Tower Light Maintenance
0x01	General Status poll	General Status poll

Note: Reserved function codes are retained to maintain equivalency with the existing QCOM protocol.

3.6.2 Response Messages

The following responses from 3rd party devices would be supported. (these are directly equivalent to the QCOM responses from EGMs):

Func Code	Solicited	3 rd Party Device Response	Equivalent QCOM Response
0x19	Yes	Program Signature Response	Program Signature Response
0x16	Yes	3rd Party Configuration Response	EGM Configuration Response
0x13	Yes	(Reserved)	EGM Game Configuration Response
0x10	Both	Event Response	Event Response
0x0F	Yes	Purge Event Poll Acknowledgment	Purge Event Poll Acknowledgment
0x0C	Both	Meter Group/Contribution Response (<i>with redefined meters</i>)	Meter Group/Contribution Response
0x0A	Yes	Multi-Game/Variation Meters Response (<i>with redefined meters</i>)	Multi-Game/Variation Meters Response
0x07	Yes	Progressive Meters Response (<i>with redefined meters</i>)	Progressive Meters Response
0x06	Yes	(Reserved)	(Reserved for DLSA - DLSA Status)
0x01	No	General Status Response	General Status Response
0x??	Both	Forward request to EGM (see note)	NEW RESPONSE

Note: The proposal is that an additional response "Forward request to EGM" would be included to enable 3rd party devices to request specific polls to be forwarded to an EGM by the Site Controller. See 3.6.4 "Forward Request to EGM Response" below.

3.6.3 Broadcast Messages

The following broadcast messages to 3rd party devices would be supported. (these are directly equivalent to the QCOM broadcast messages to EGMs):

Func Code	3rd Party Controller Broadcast Message	Equivalent QCOM Broadcast Message
0xFF	Current Date and Time and	Current Date and Time and

	Broadcast Information	Broadcast Information
0x02	(Reserved)	Linked Progressive Current Amounts
0x03	General Promotional Message	General Promotional Message
0x04	3rd Party Poll Address Configuration	EGM Poll Address Configuration
0xFE	Site Details	Site Details

3.6.4 Forward Request to EGM Response

In request to a poll from the 3rd Party Interface Controller the 3rd party device would format the following messages for onward transmission to the requested EGM. The 3rd Party Interface Controller would then pass these messages to the QCOM controller via the 'bridge'. The QCOM controller would establish the validity of the message e.g. whether the 3rd party device is authorised to send such a message to the EGM and, if authorised, send the message onto the requested EGM.

Only the following messages would be authorised for onward transmission to EGMs on a device-by-device basis (e.g. a venue management system could not request an electronic cash transfer):

Func Code	Message Description
0x2D	EGM Parameters (LWIN etc) [Possibly]
0x24	Electronic Cash Transfer Lockup request
0x23	Electronic Cash Transfer from EGM Lockup Request
0x22	Electronic Cash Transfer to EGM
0x27	System Lockup Request
0x08	Specific Promotional/Advisory A
0x07	Specific Promotional/Advisory B
0x05	EGM Tower Light Maintenance (for completeness but NZ EGM's do not have tower lights)
0x02	Linked Progressive Current Amounts

The message to the Site Controller requesting the forwarding to an EGM would require the EGM to be identified in some way either through the device ADR or the PGID reference.

3.6.5 Meters

In third party systems where value is not transferred to EGMs for inclusion in the GMP calculation by the EMS additional meter groups it would be necessary for new meter to be defined that comply with the general requirements for meters defined in section 12 of "Local Area EGM Communications Protocol (QCOM)" This metering information could then be passed back to the EMS system from the 3rd party device via the Meter Group/Contribution Response (function code 0x0C)

Definition of the mapping of meters to meter groups in the 3rd Party protocol would be performed in the development of the 3rd Party Protocol Standard to be developed by DIA.

3.7 Security

Any 3rd party device connected to the EMS would require the same levels of approval by DIA that applies to Site Controllers and EGMs.

It would be necessary for the 3rd Party Interface Controller to authenticate the device in a similar manner to that applied to EGMs.

Control of configuration of 3rd party devices would be necessary from the EMS host computer via the 3rd Party Interface Controller.

It would be expected that all 3rd party devices were constructed in a similar manner to Site Controllers and the relevant aspects of the minimum technical requirements of Site Controller should be adopted.

4 Specific 3rd Party Devices

We envisage at this stage that the following 3rd party devices will need to be supported by the EMS.

- Cashless Gaming
- Jackpot Controllers
- Venue Management systems (VMS)

It would be necessary for a 3rd Party Interface to be provided to the EMS to enable the provision of cashless Gaming and Jackpot Controllers. VMS may not require this interface.

Minimum standards will be developed for linked jackpots and cashless systems supplied by either the monitors and/or 3rd party equipment providers. It is expected that these standards will align closely with the existing QOGR requirements.

4.1 Cashless Gaming Systems

The integration of 3rd party cashless systems into the EMS to allow cash transfers to EGMs.

4.1.1 Background

Only one form of cashless gaming system currently exists in New Zealand where the card swipe capability is integrated into the EGM. These systems interface directly to the machine and any credits introduced would be reported to the EMS via the Site Controller.

No other cashless systems are approved by DIA at this time however provision could be made in the EMS, via the Site Controller, to support any new 3rd party devices if manufactures were to offer them.

It is proposed that any 3rd party cashless system would be implemented utilising the 3rd Party Interface for the transfer of cash via the Site Controller to the EGM

4.2 Jackpot Systems

The integration of 3rd party jackpot controllers into the EMS to the extent that GMP for venues can be accurately established.

4.2.1 Background

There are two types of pulse counter based jackpot systems implemented in New Zealand. One type of system is integrated with EGMs and payouts are made through the EGM. This system is likely to be capable of reporting payouts to the EMS.

All other types determine when a linked jackpot is struck and advises a player through lights, displays and alarms, which are independent of the EGM. Payouts are performed manually.

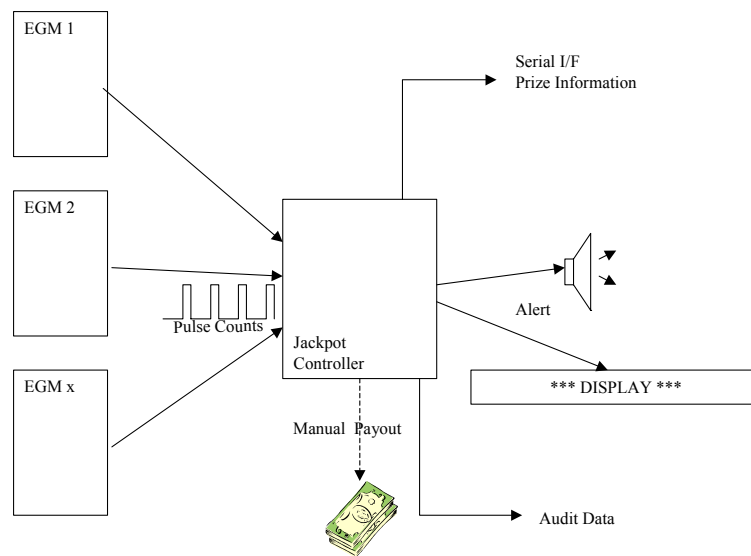

These systems are unlikely to be able to contribute to the reconciliation of GMP, as there is no interface available back into a Site Controller for onward transmission to the EMS.

4.2.2 Jackpot Meters and Control Parameters

It would be necessary to report specific meters and control parameters for jackpot controllers that are not available in the EGM message set. This data have to be capable of being passed to and from a jackpot controller without compromising the integrity of the system.

4.3 Venue Management Systems

To provide a means by which a venue management capability can be made available to venue operators by allowing access to the relevant system data. It is not the purpose of this document to define the requirements for a VMS.

4.3.1 Background

VMS provide an independent monitoring capability for venue operators. There is likely to be no GMP related function that is of interest to the EMS and unlikely to be any requirement for VMS to provide data into the EMS. Therefore VMS could be seen as stand-alone to some degree and do not require the use of the 3rd Party Interface.

4.3.2 Options

There are a number of possible options available to venues that could possibly use the 3rd Party Interface:

1. Retain whatever existing VMS capability currently implemented by the venue.

2. Implement a VMS that monitors or ‘sniffs’ the QCOM bus only.
3. Implement a VMS that monitors or ‘sniffs’ the QCOM bus and reports on the 3rd Party Interface.

4.3.2.1 Retention of Existing Capability

Venues’ existing VMS capabilities may be used. However these capabilities are limited when compared to other options that may be available to them. Venues adopting this option would be unlikely to impact on the provision of an EMS.

4.3.2.2 QCOM “Sniffer” Bus Device

VMS could be implemented by introducing a ‘sniffer’ device on the QCOM bus to monitor meter and event traffic being reported back to the Site Controller by EGMs.

Other than meeting the requirements of section 9 of the document “EGM Communications Interface and LAN Requirements V2.0”, which requires approval by DIA, the specification of such a device would be the responsibility of the manufacturer of the 3rd party VMS.

A VMS that solely monitors the QCOM bus would be an entirely passive device and would not allow any control of the EGM from the EMS.

4.3.2.3 3rd Party Interface

In addition to a ‘sniffer’ device monitoring the QCOM bus to capture meter data as it is being reported to the Site Controller the 3rd Party Interface could be utilised to allow venue operators to send such things as promotional messages to EGMs via the Site Controller.

5 APPENDIX A – Forward Request Function

The 3rd Party Interface needs the adoption of a standard that allows a 3rd party device communication to EGMs for agreed message types. The Site Controller would validate the message to the source device and determine if it is authorised to forward the message before repackaging and forwarding to the other device.

Forward Request

The new response could be in the form that in response to a poll the device sends an application layer packet

<FUNC><MSD>

Where FUNC is a new function Forward (FWD) (for example 0x7F)

MSD takes the form

<LEN> <ADRS> [message to be forwarded]

Where LEN is the length of the overall message. It does not include the function code byte and the Data Link Layer Overhead (5 Bytes)

ADRS is the address of the EGM for the message to be forwarded (this may be PGID if the device cannot determine ADRS)

[Message to be forwarded] is a complete application layer message to go to device at ADRS.

An example for a 3rd Party jackpot controller to set the lowest light flashing on EGM No 7 the following bytes would be sent (ignoring the data link layer)

FWD Request			Message to be forwarded			
FUNC	LEN	ADRS	FUNC	LEN	FLG1	FLG2
0x7F	0x05	0x07	0x05	0x02	0x00	0x01

The Site Controller then determines the validity of the request and if the device is authorised to request the information to be transmitted to EGM No. 7 the Poll message is sent.